

Introducing the MAXIMA-K 1K series maximum efficiency, single-stage liquid ring vacuum pump.

- ◆ Reliable heavy-duty design, built to rigid quality standards.
- ◆ Variable discharge port enables pumps to operate at maximum efficiency over the entire vacuum range.
- ◆ Shaft sleeves are standard, virtually eliminating the possibility of shaft wear.
- ◆ Available in different materials to suit your application.
- ◆ Standard sealing is packed gland, mechanical seals available.
- ◆ Heavy duty bearings mounted external to the pumping chamber, eliminating potential bearing failure due to process contamination.
- ◆ Low operating speeds ensure an extended life cycle.
- ◆ The pump can handle large amounts of condensable vapors which enhances the performance significantly.
- ◆ No metal-to-metal contact, only one moving part.
- ◆ The pumps can handle carry-over of liquids and/or soft solids without causing damage to the internal parts.
- ◆ The design allows operation with various seal fluids.
- ◆ Low operating noise levels are in the 75 - 85 dBA range.

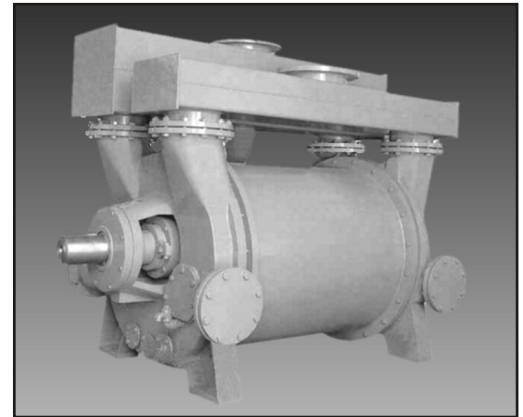

Performance characteristics

Nominal capacity:	12000-18000CFM
Motor range:	500-850HP
Speed range:	220-312RPM
Maximum vacuum:	24" Hg/150 Torr
Weight (bare-shaft):	27060Lbs/12300kg
Maximum gas inlet temp.:	212°F/100°C
Noise level(at 3ft):	80-85 dBA

Materials of construction/Seal code

Mat.code	4**	7*	
Casing	316 S/S	cast iron	other materials available upon request
Portplate	316 S/S	carb.steel	
Impeller	316 S/S	carb.steel	
Shaft	316 S/S	carb.steel	
Seal code	P***	P***	

* standard material pumps protected by 420 SS shaft sleeves.

** 316 SS pumps protected by 316 SS shaft sleeves

*** P = standard seal is packed gland, other seal materials available upon request.

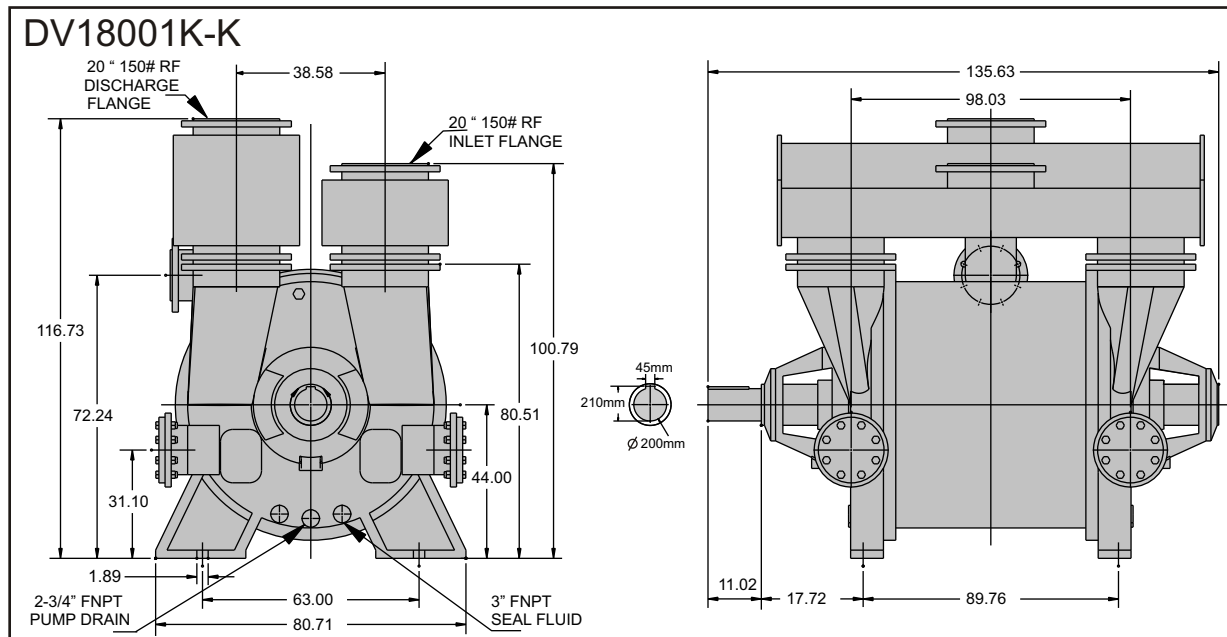

Performance charts see next page

Dimensions (inches) not binding. Subject to change without notice. Companion flanges sold separately.

DV18001K-K

