

DuraVane^{HV} high vacuum pumps (RVR-series): Lubricated rotary vane pumps for operating in the pressure range of 7.5×10^{-1} down to 7.5×10^{-3} Torr*. (Partial final pressure range 3.8×10^{-1} to 3.8×10^{-3} Torr - McLeod). The pumps feature a compact design with very quiet operation (54-64dBA). Typical applications include refrigeration, air-conditioning and other high vacuum requirements.

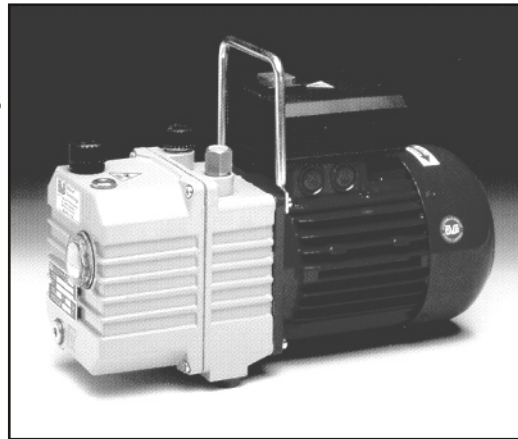

Performance characteristics	
Number of stages:	2
Displacement:	3CFM
Final pressure:	7.5×10^{-3} Torr
Partial (McLeod):	3.8×10^{-3} Torr
with gas ballast:	1.5×10^{-1} Torr
Motor:	0.5HP/50/60Hz TEFC
Voltage:	115/230V/1phase
Speed:	1800RPM
Noise level (at 3ft):	54dBA
Oil reservoir cap.:	0.25qt
Oil type:	Duratex68
Weight:	27Lbs
Inlet conn.:	1/4" NPT

- Heavy duty construction.
- Compact design, small footprint.
- Multi-frequency motor.
- Gas ballast valve is standard.
- Low noise level.
- Low maintenance.
- Air-cooled design.
- Direct drive.
- Simple to install.

* = Total final pressure unless otherwise specified.

RVR003H

Based on 760 mm Hg (Torr) barometric pressure.
Inlet temperature 70° deg. F.

--- with gas ballast

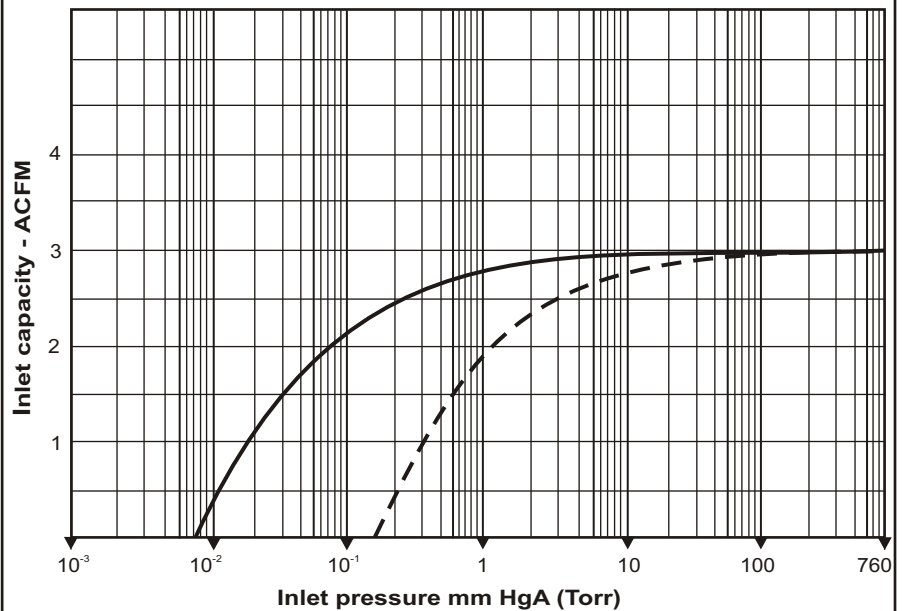

RVR003H

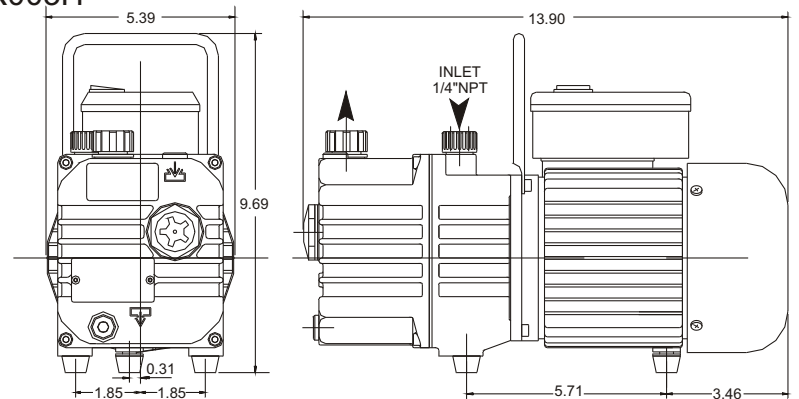

Information contained in this document is for reference only. Subject to change without notice.