

Why more and more customers are switching to the *Vmax* system:

- ✓ The only system on the market with a **full 3-year warranty!**
- ✓ New, patented, **high-efficiency DX-5 separator** eliminates oil carry-over concerns.
- ✓ Rugged, **high-quality, industrial system**, offering years of **trouble free operation**.
- ✓ **Extended-life seal-fluid** is not used as a lubricant. Change interval is not critical, resulting in a minimum of **10,000 hours of continuous operation**.
- ✓ **Continuous operation over the full vacuum range** without overheating.
- ✓ **Carry-over** of soft solids and/or minimal amounts of liquid **does not cause damage** to the internal parts of the pump.
- ✓ **Electrical control panel is standard**.
- ✓ **Air-cooled design is standard** with water-cooling available at no extra charge.
- ✓ Now available with **Variable Frequency Drive** resulting in lower power consumption.

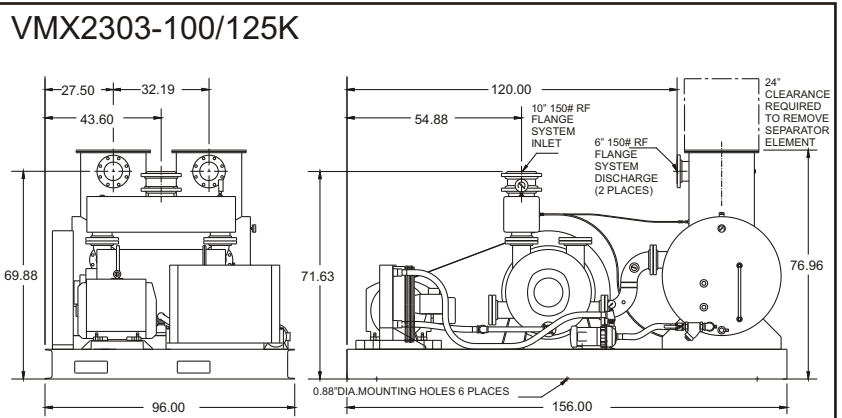
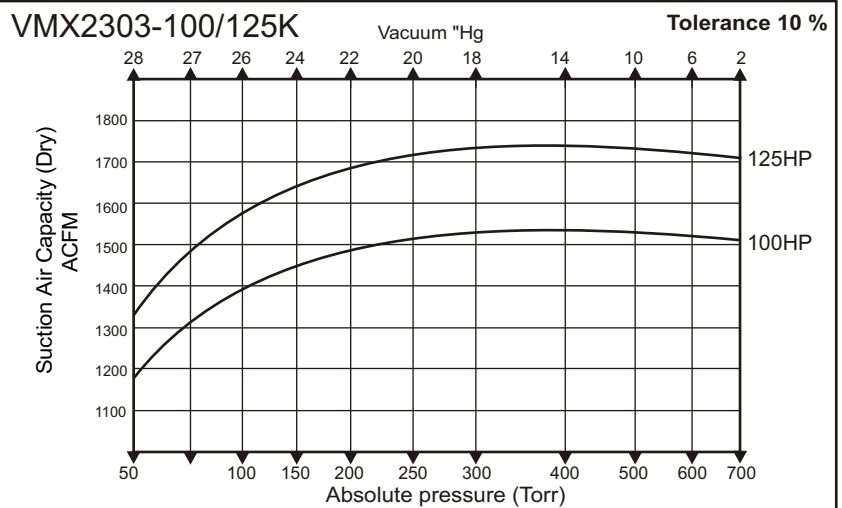
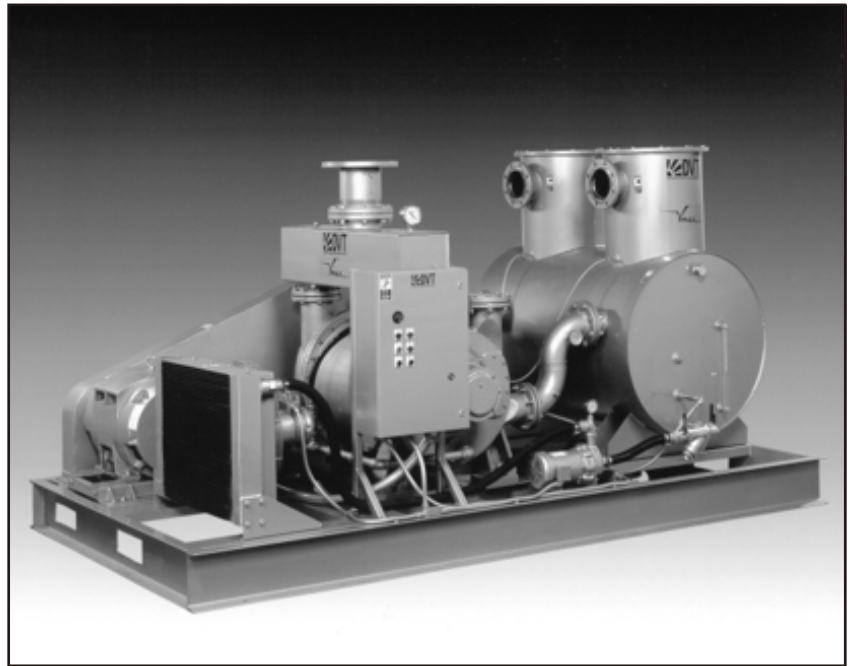

Performance Characteristics

Nominal capacity:	1600/1800CFM
Motor:	100/125HP
Speed:	625/710RPM
Maximum vacuum:	28"Hg
Weight:	consult factory
Maximum gas inlet temperature:	212°F/100°C
Oil capacity:	consult factory

Performance based on atmospheric pressure equal to 29.92"Hg

Information contained in this document is for reference only. Subject to change without notice.