

Two-stage vacuum pump
DV0076B-DA

Presenting the **TITAN** SERIES
two-stage liquidring
vacuum pump.

Why should you consider this vacuum pump for your application?

- ◆ Designed for heavy duty applications.
- ◆ Optional monoblock adaptor available, which utilizes NEMA C-face motors.
- ◆ Manufactured to ISO 9001 standards.
- ◆ Low operating noise level.
- ◆ Heavy duty bearings mounted external to the pumping chamber.
- ◆ Features single face mechanical seals as standard.
- ◆ Double mechanical seals are available upon request.
- ◆ Virtually no maintenance is required.
- ◆ Pumps are available in different materials to suit your application.
- ◆ Capable of handling saturated gas mixtures.
- ◆ Capable of handling small amounts of liquids.
- ◆ Only one moving part.
- ◆ Can operate using various seal-fluids.

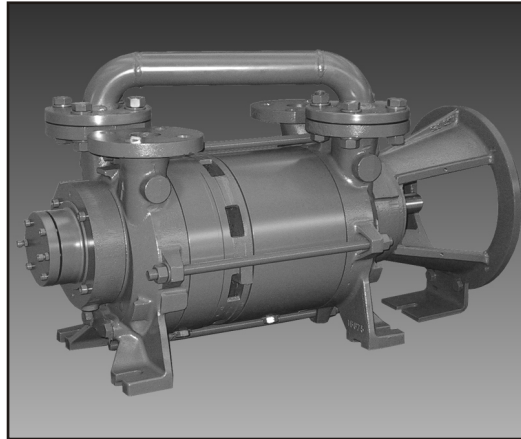

Performance characteristics
 Nominal capacity: 75CFM
 Motor: 50Hz/4HP/3kW
 60Hz/5HP/3.8kW
 Speed(RPM): 50Hz/1450
 60Hz/1750
 Max.vacuum: 29"Hg/25Torr
 Weight (bare-shaft): 148Lbs/67kg
 Max. gas inlet temp: 212°F/100°C
 Max.noise level(at 3ft): 68dBA
Performance based on dry air, seal-water temperature 60°F and atmospheric pressure of 29.92"Hg.

DV0076B-DA

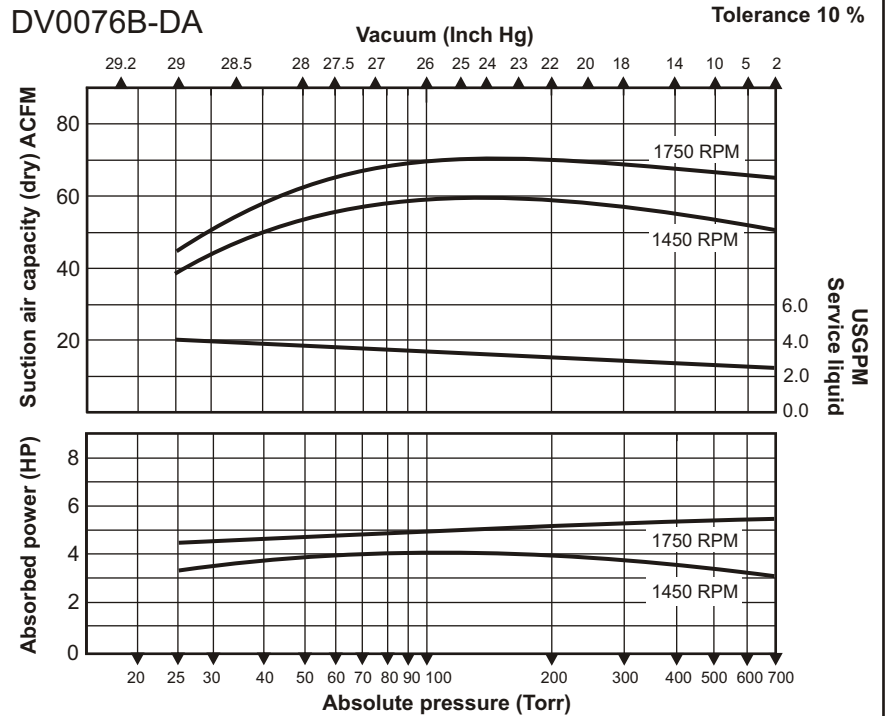

Materials of construction/Seal code				
Mat.code	1	2	3	4
Casing	NA	cast iron	cast iron	316SS
Portplate	NA	cast iron	cast iron	316SS
Impeller	NA	bronze	316 SS	316SS
Shaft	NA	420 SS	420 SS	316SS
Seal code	NA	A*	A*	B*

A= standard mechanical seal with Viton elastomer
 B= standard mechanical seal with Teflon elastomer
 * = other seal materials available upon request.

DV0076B-DA

