

Presenting the **TITAN** SERIES
*two-stage liquidring
vacuum pump.*

Why should you consider this vacuum pump for your application?

- ◆ Designed for heavy duty applications.
- ◆ Manufactured to ISO 9001 standards
- ◆ Low operating noise level.
- ◆ Heavy duty bearings mounted external to the pumping chamber.
- ◆ Features single face mechanical seals as standard, double mechanical seals available upon request.
- ◆ Virtually no maintenance is required.
- ◆ Pumps are available in different materials to suit your application.
- ◆ Capable of handling saturated gas mixtures.
- ◆ Capable of handling small amounts of liquids.
- ◆ Only one moving part.
- ◆ Can operate using various seal-fluids.

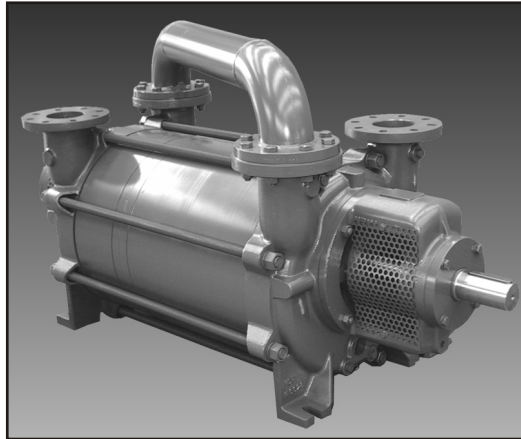

Performance characteristics
 Nominal capacity: 1000CFM
 Motor: 60 - 100HP
 Speed: 950 - 1150RPM
 Max.vacuum: 29"Hg/25Torr
 Weight (bare-shaft): 1200Lbs/545kg
 Max. gas inlet temp: 212°F/100°C
 Max.noise level(at 3ft):82 dBA
Performance based on dry air, seal-water temperature 60°F and atmospheric pressure of 29.92"Hg.

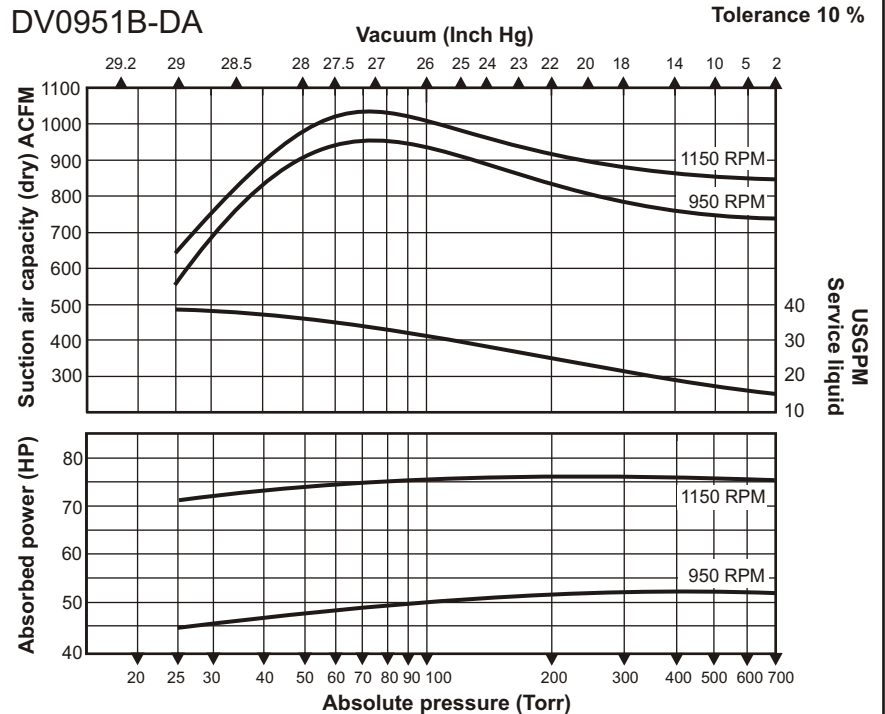

Materials of construction/Seal code				
Mat.code	1	2	3	4
Casing	NA	cast iron	cast iron	316 SS
Portplate	NA	cast iron	cast iron	316 SS
Impeller	NA	bronze	316 SS	316 SS
Shaft	NA	420 SS	420 SS	316 SS
Seal code	NA	A*	A*	B*

A= standard mechanical seal with Viton elastomer
 B= standard mechanical seal with Teflon elastomer
 * = other seal materials available upon request.

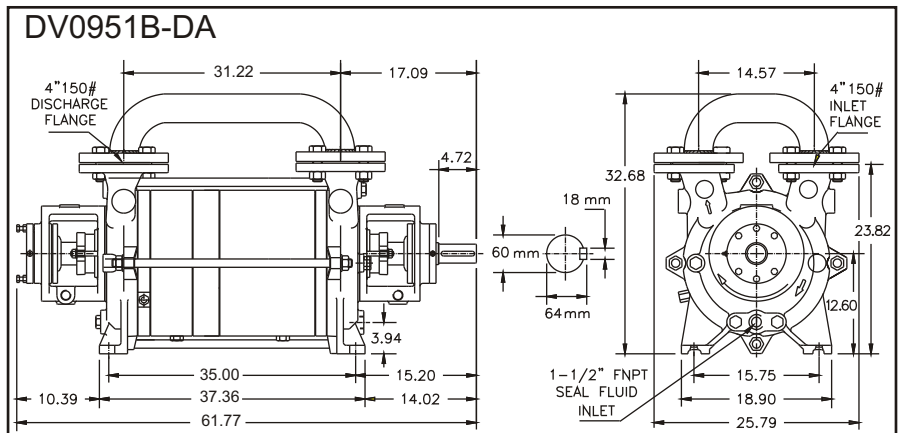

Dimensions (inches) not binding. Subject to change without notice. Companion flanges NOT included.