

DuraVane oil-free rotary vane pumps are heavy-duty compact motor-mounted units, extremely reliable for many industrial applications. Efficient cooling is ensured by a powerful centrifugal fan. The pump can also operate as a low pressure compressor.



Performance characteristics

Displacement: 71CFM
 Final vacuum: 27"Hg(75Torr)
 Motor: 5HP/60HzTEFC
 Voltage:208/230/460V/3phase
 Speed: 1800RPM
 Noise level(at 3ft): 77dBA
 Weight: 202Lbs
 Inlet conn.: 1 1/2"NPT
 Discharge conn.: -

(exhaust silencer is standard)

- Fewer vanes than other oil-free rotary vane vacuum pumps.
- High-tech, self-lubricating graphite composite vane material.
- Longer vane life and less vane replacement.
- Heavy duty construction.
- Compact design, small footprint.
- Low noise level.
- Air-cooled design.
- Direct drive.
- Simple to install.

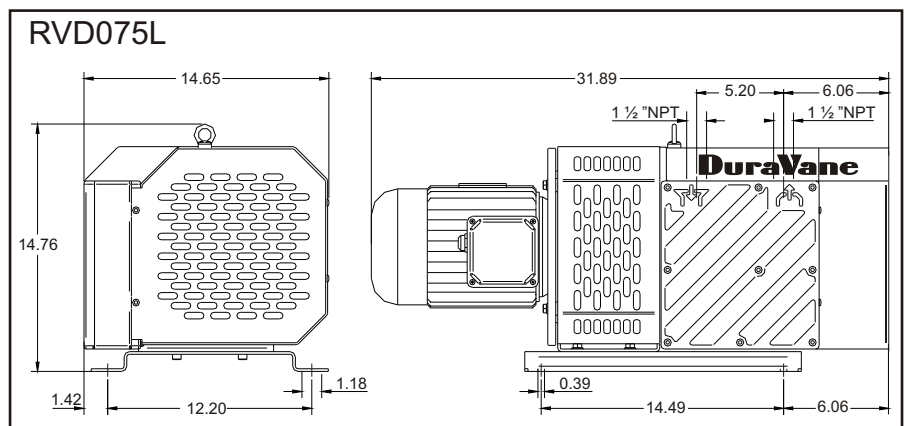
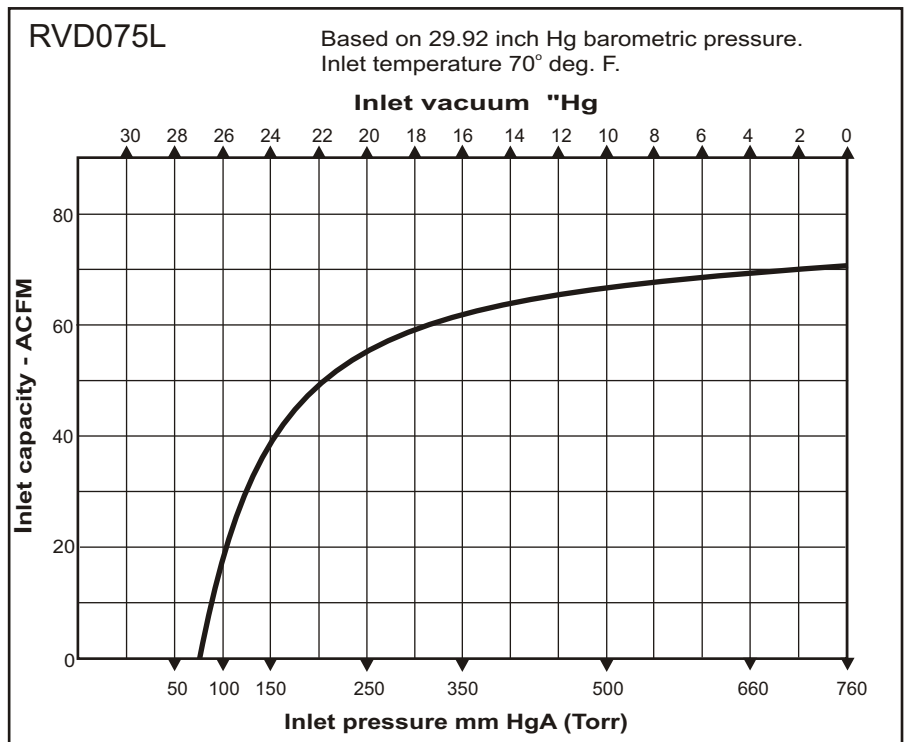

Information contained in this document is for reference only. Subject to change without notice.