

**DuraVane** oil-free rotary vane pumps are heavy-duty compact motor-mounted units, extremely reliable for many industrial applications. Efficient cooling is ensured by a powerful centrifugal fan. The pump can also operate as a low pressure compressor.



**Performance characteristics**

Displacement:	100CFM
Final vacuum:	27"Hg(75Torr)
Motor:	7.5HP/60HzTEFC
Voltage:	208/230/460V/3phase
Speed:	1800RPM
Noise level(at 3ft):	78dBA
Weight:	220Lbs
Inlet conn.:	1 1/2 "NPT
Discharge conn.:	-

(exhaust silencer is standard)

- Fewer vanes than other oil-free rotary vane vacuum pumps.
- High-tech, self-lubricating graphite composite vane material.
- Longer vane life and less vane replacement.
- Heavy duty construction.
- Compact design, small footprint.
- Low noise level.
- Air-cooled design.
- Direct drive.
- Simple to install.

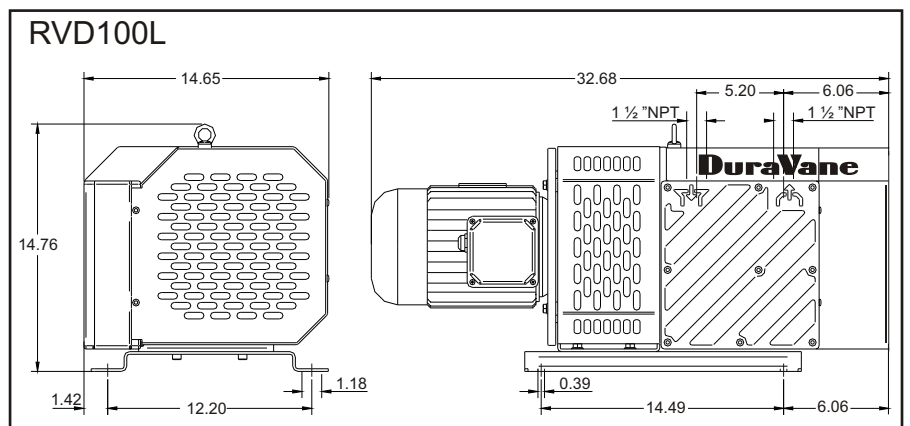
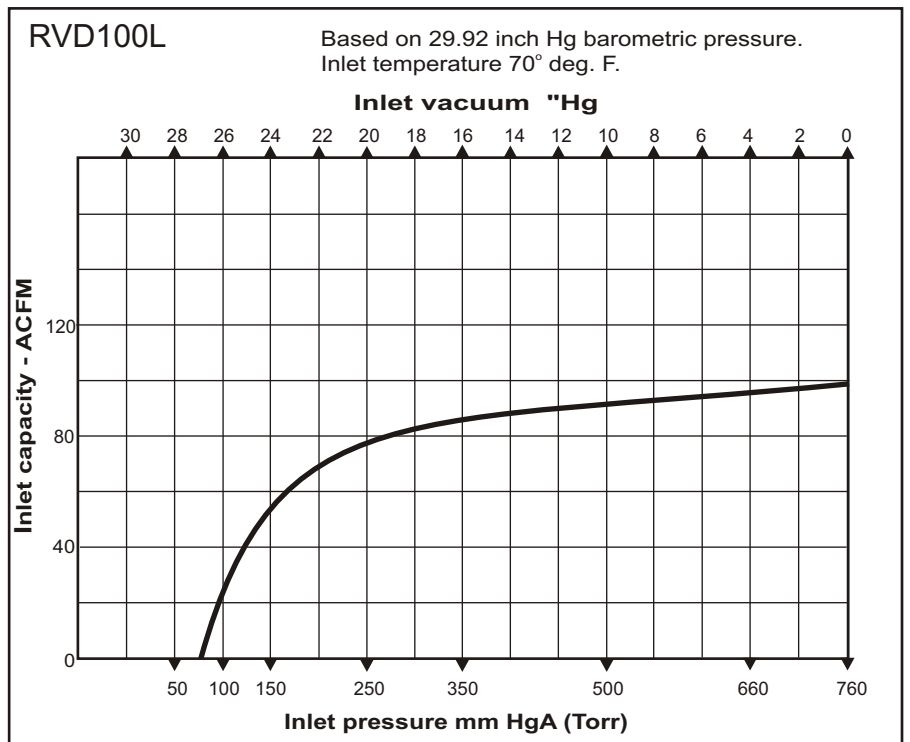

Information contained in this document is for reference only. Subject to change without notice.