

ROBO **DRAIN**

Pneumatically Powered Condensate Removal System

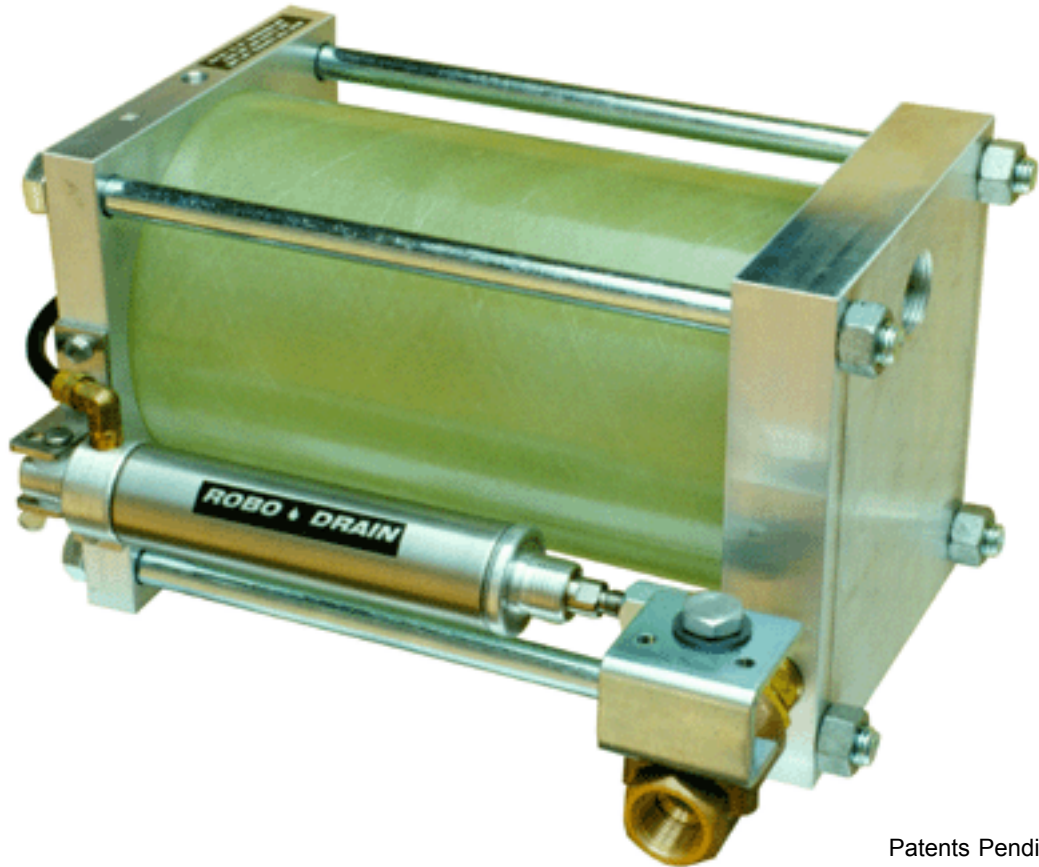

Patents Pending

Features....

- ◆ See-Through Vessel
- ◆ Fully Pneumatic
- ◆ No Wasted Air
- ◆ Low Profile
- ◆ Made in U.S.A.
- ◆ Ball Valve Stem Support System
- ◆ Ideal for Oil/Water Separators
- ◆ Non-Clogging Ball Valve
- ◆ No Strainers to Clean
- ◆ Operates On Demand

AIR SYSTEM PRODUCTS, INC.

"The Best in Condensate Drain Technology"

Bulletin RD401

DESIGN

The **ROBO DRAIN** is the ultimate demand operated drain. The unit is fully automatic, no electricity is required. Its low profile gives you the advantage of installing it in areas where the vessel to be drained is only a few inches from the ground. The **ROBO DRAIN's** design also eliminates the need for the installation of a vent line for most applications. A unique air valve design uses a magnetic force to ensure both a positive opening and closing that will prevent any air loss. The magnetic force is cleverly positioned away from the condensation level to prevent any attraction of metal particulate. An innovative ball valve support and positioning system prevents the side-loading problem which otherwise would cause premature sealing failure around the valve stem. Rifle drilled discharge porting ensures that scale and rust will exit through a full ported 1/2" ball valve. The **ROBO DRAIN** will not clog --- no strainer required.

OPERATION

Condensation enters through one of two ports. The see-through vessel allows visual inspection of the condensation as it rises. A stainless steel float rises with the level of condensation and positions a magnetic force over the valve housing. When the liquid level reaches the desired level, the magnet in the valve housing snaps upward and allows air to pass through a stainless steel seat. The air then moves to a non-lubricated air cylinder causing it to extend and open the ball valve. Condensation, scale and rust particles rapidly exit the unit. Before any air is lost, the float removes the magnetic force from the valve and the seat is covered with a Viton seal. A powerful spring returns the air cylinder to its normal position and rotates the positive closing ball valve back to its normally closed position. The pilot air used to actuate the air cylinder is isolated from the air in the drain's reservoir.

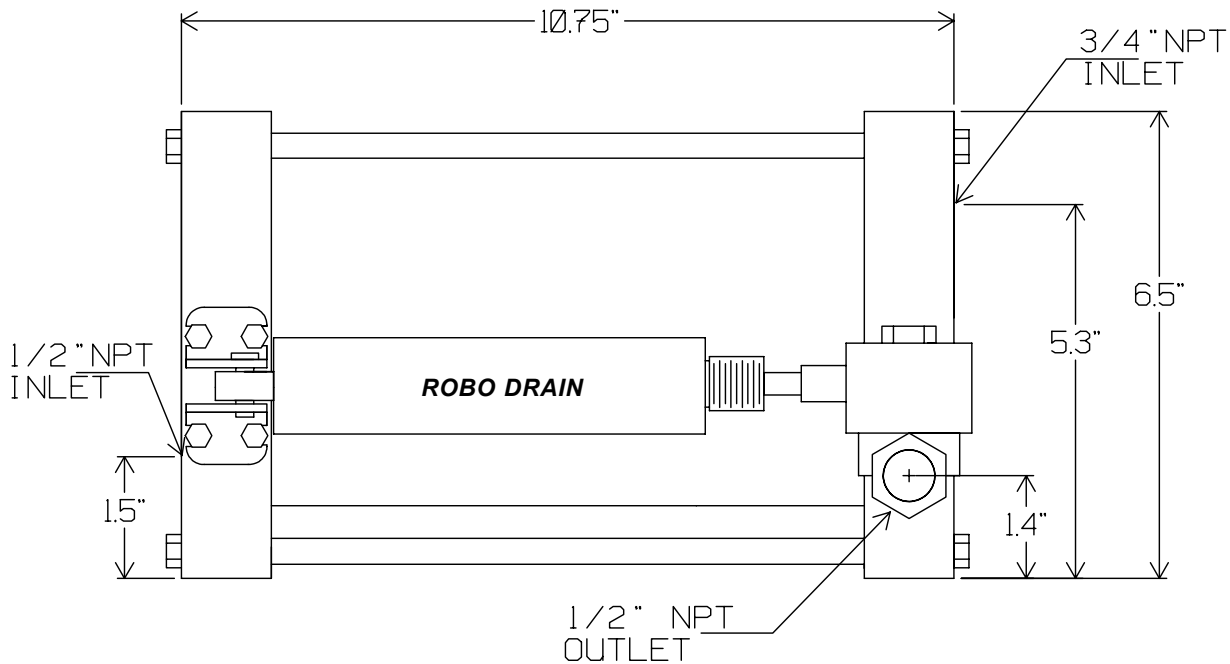

SPECIFICATIONS

Inlets: (2) 3/4" NPT and 1/2" NPT
Outlet: 1/2" NPT
Power: Clean, Dry Compressed Air 80 to 130 PSI
Pressure: 0 to 200 PSI
Operating Temperature: 32° to 180° F.
Weight: 16 lbs.
Discharge: 24 Ounces per cycle.

MATERIALS

Reservoir: Aluminum and Composite
Valve: Bronze w/SS. Ball and Stem
Float: Stainless Steel
Seat: Stainless Steel
Seal: Viton

OPTIONS - Consult factory

All design specifications are subject to change without notice.

Distributed by:

AIR SYSTEM PRODUCTS, INC.