

Oil-Free Air

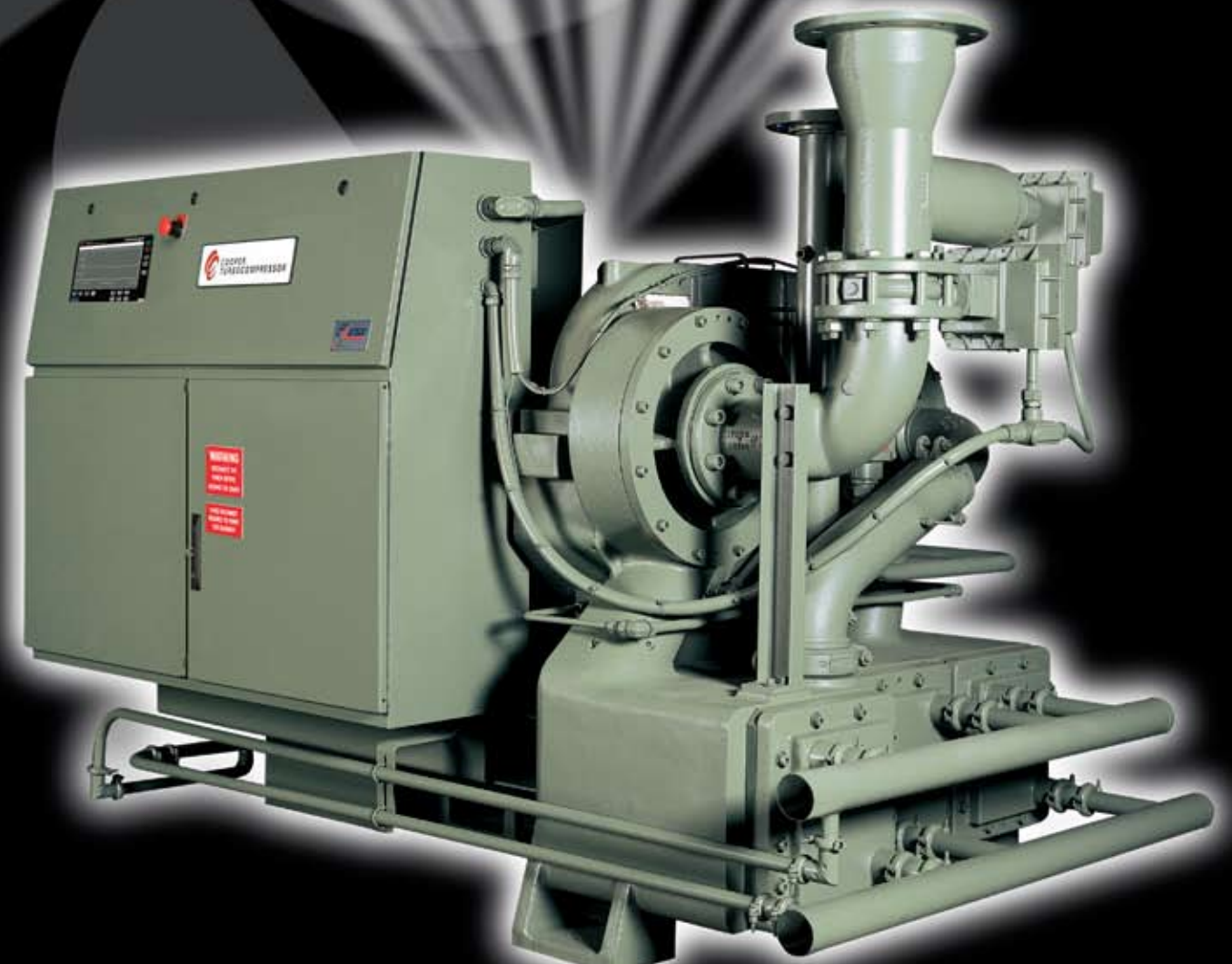

Oil-Free Air



**Turbo Air® 2000
Centrifugal Compressors**



Proven Performance Worldwide



One 350 HP (260 KW) Turbo Air® Compressor installed at an automotive facility.



Six 350 HP (260 KW) Turbo Air® Compressors installed at an automotive facility.



Two 200 HP (150 KW) Turbo Air® Compressors installed at a chemicals facility.



Two 1250 HP (930 KW) Turbo Air® Compressors installed at a chemicals facility.



Three 200 HP (150 KW) Turbo Air® Compressors installed at an electronics facility. Three 500 HP (370 KW) Turbo Air® Compressors are also installed.



Two 300 HP (225 KW) Turbo Air® Compressors installed a water treatment facility.



One 300 HP (225 KW) Turbo Air® Compressor installed at a major university for instrument air.



Four 1250 HP (930 KW) Turbo Air® Compressors installed at a glass facility.



One 10,000 HP (7455 KW) MSG® Air Compressor installed at an air separation facility. One 11,000 HP (8200 KW) MSG® combination Nitrogen Feed/Recycle Compressor is also installed.

Cooper Turbocompressor — The Leader in Oil-Free, Centrifugal Compressors

Cooper Turbocompressor is a leading manufacturer of modern, high efficiency, oil-free centrifugal compressors. Cooper Turbo-compressor's refinement of the design of this technologically superior style of compressor has resulted in the continuing worldwide replacement of older, less efficient, more costly compressors used to supply air for manufacturing and process applications. The success of our Turbo Air® and MSG® Turbocompressors for these applications has produced over 6,000 installations worldwide.

Cooper Turbocompressor continues in the forefront of state-of-the-art compressor design with fully integrated facilities that are dedicated entirely to the engineering and manufacturing of centrifugal compressors.

ISO 9001 certification is testimony to Cooper Turbocompressor's commitment to be the best in the compressor industry. It means quality is an all-encompassing, company-wide attitude.

Cooper Turbocompressor offers a broad line of oil-free centrifugal air compressors, each designed for long lasting performance, easy operation and convenient service. This brochure details the Turbo Air® 2000 Centrifugal Compressor designed for nominal flows from 550 CFM to 1700 CFM. Other configurations are available to 70,000 CFM.

Industries worldwide depend on Cooper Turbocompressor for efficient and reliable oil-free air.

- Textiles
- Food and Beverage
- Automotive
- Snowmaking
- Refineries
- Glass Manufacturing
- Iron and Steel
- General Manufacturing
- Water Treatment
- Pharmaceuticals
- Chemicals
- Bottles
- Industrial Gases
- Power Generation
- Electronics
- Pulp and Paper
- Transportation Equipment
- Aerospace



Cooper Turbocompressor offers a complete range from 70,000 CFM (2,000 M³/MIN), 22,000 HP (15,000 KW) to 550 CFM (16 M³/MIN), 150 HP (112 KW).



Fully integrated manufacturing facilities located in Buffalo, New York, USA are dedicated entirely to centrifugal compressors.



Cooper Turbocompressor is located minutes from spectacular Niagara Falls, one of the world's most popular tourist attractions.

Why Cooper Turbocompressor?

Oil-Free Air

- Prevents oil contamination of your system.
- Removes the potential for compressed air pipeline fires caused by oil carryover.
- Eliminates costly waste disposal problems associated with oil-laden condensate.
- Eliminates the expense and associated maintenance requirements of oil removal filters, since no oil enters the compressed air stream in the compressor.

High Reliability

- Thrust loads absorbed at low speed.
- No wearing parts.
- Non-contact air and oil seals.
- Stainless steel compression elements.
- Conservative high quality gear design.
- Unlimited life pinion bearing design.

Lowest Cost Operation

- True unloading capability.
- Energy savings and increased uptime translate to minimum operating life cycle costs.
- Excellent part-load efficiencies for any operating load.
- No sliding or rubbing parts in the compression process causing wear and thereby efficiency loss.

Easy Operation

- Vantage™ High Performance Compressor Control System, the compressor industry's most advanced control system, is standard for ease of operation.
- Totally automatic operation for any operating condition.
- Self diagnostics.
- Quiet operation.

Easy Maintenance

- No wearing parts requiring periodic changes or replacement in the compression elements.
- No oil removal filters to clean.
- Accessible horizontally split gear box for quick inspection.
- Intercooler and aftercooler bundles are easily removed for cleaning.
- Water in the tube design intercoolers and aftercooler allows for simple mechanical cleaning.

Simple Installation

- Complete package including aftercooler, controls, motor, lubrication system, and cooling water manifold.
- Minimum number of external connections.
- Compact design requires minimum floor space.
- Package starter options available in full voltage, Y delta or solid state configurations.
- Packaged discharge check valve option available to eliminate costly field installation.
- Meets OSHA's sound level requirements.



The Lowest Compressor Operating Life Cycle Cost

Operating Life Cycle Cost (OLCC)

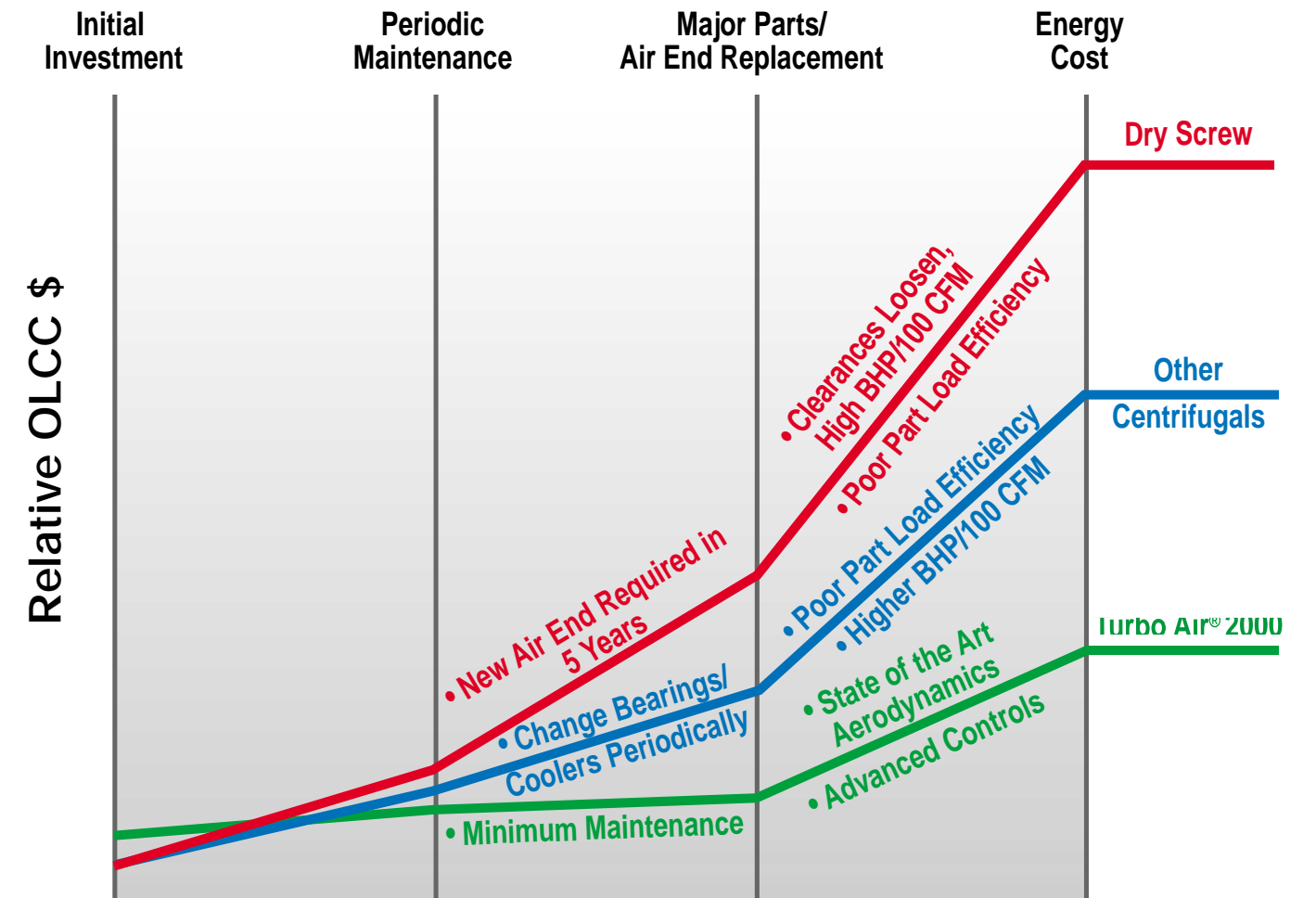

The Turbo Air® 2000 Compressor is engineered with three stages of compression to deliver greater flow for every KW. The system provides much better operating economy than rotary screw or other centrifugal compressors.

Compared to other machines of similar capacity, the Turbo Air® 2000 Compressor has the best KW-to-flow ratio for ultimate power savings.

This alone can significantly speed up payback on your initial investment - and the savings continue to build the more you use the Turbo Air® 2000.

Turbo Air® 2000 Compressors are the most efficient oil-free compressors at full load, part load, and no load.

Turbo Air® 2000 Centrifugal Compressors

The most advanced package available -

Easy, low cost installation and operation. Includes control center, built-in aftercooler, cooling water manifold, inlet filter/ silencer and optional packaged check valve.



Starter Options (Packaged) - Packaged starter options available in full voltage. Y delta, or solid state configurations.



Vantage™ High Performance Compressor Control System - The compressor industry's most advanced control system is standard, offering greater turndown and true system pressure control for significant energy savings.



Lubrication System - Self-contained, low pressure system.

Seals - Non-contact, non-wearing labyrinth air and oil seals. No buffer air required for oil-free air. Eliminates the need for periodic replacement of carbon seals.

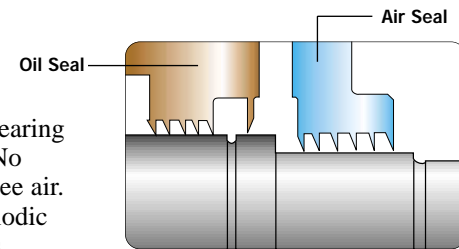

Horizontal Split Gear Box - Allows for easy access when customer's maintenance policy requires periodic inspection.



Impellers - Advanced design combines the best features of a semi-radial and backward leaning impeller.

Vaned Diffusers - Matching diffusers for superior efficiency.

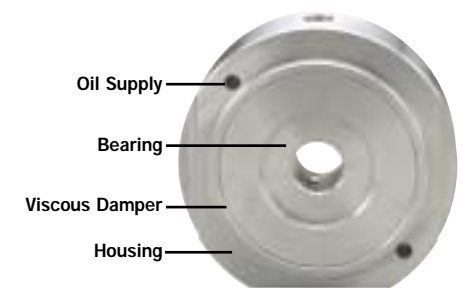

Superior Pinion Bearing Design (patent pending) - For unlimited life and operation at any load.



Intercoolers/Aftercooler - Water-in-tube intercooler and aftercooler bundles slide out for easy inspection and cleaning.

Airflow Diagram - 3 Stages of Compression

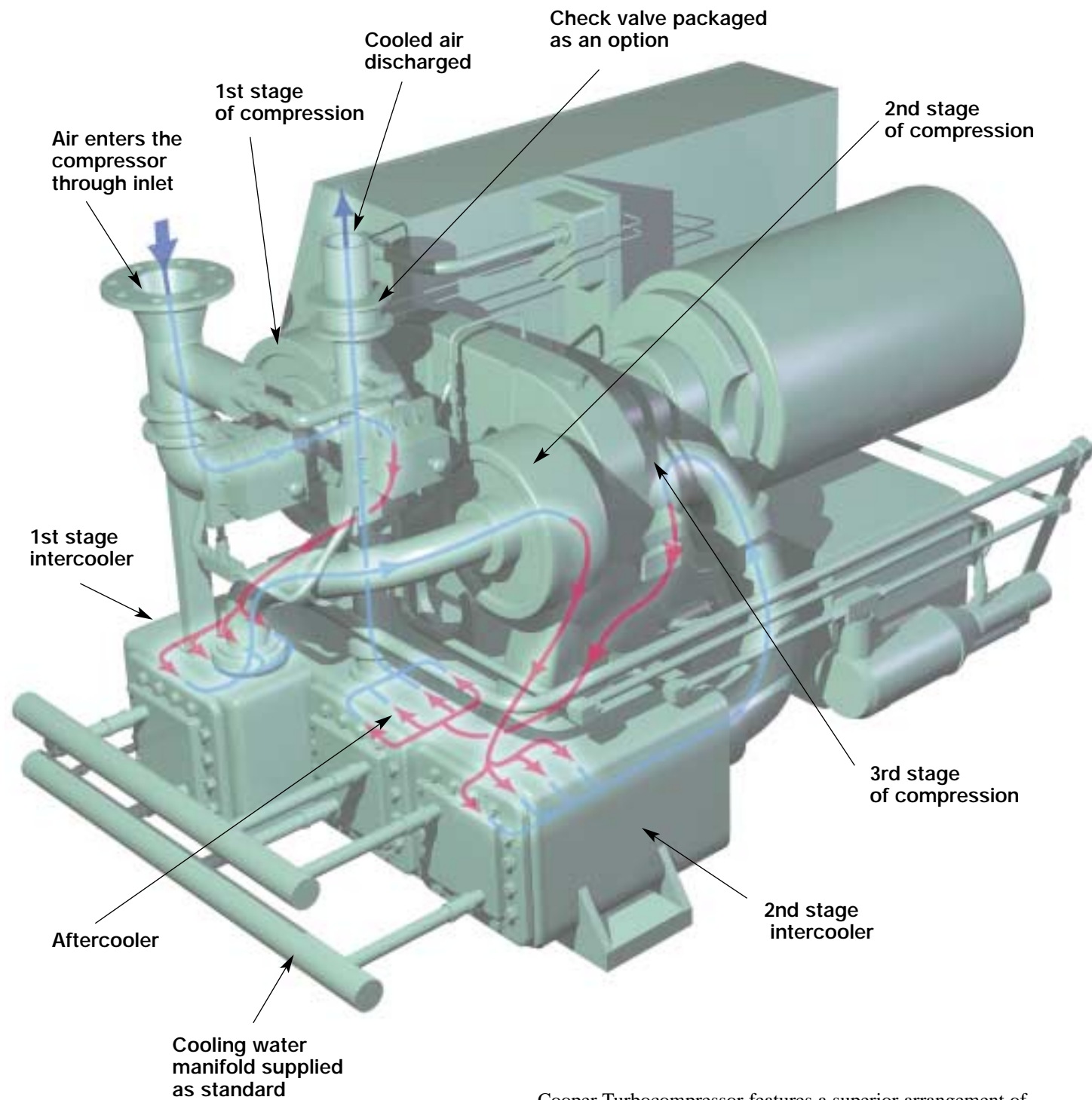

Cooper Turbocompressor features a superior arrangement of air flow components. Air movement through each stage of the compressor is directed so turbulence is reduced. Energy is added to the air in each stage which increases the pressure. Air is cooled after every stage to assure high efficiency. A built-in aftercooler eliminates the need for a separate pipeline type cooler.

VANTAGE™ HIGH PERFORMANCE CONTROL SYSTEM The industry's most advanced control solution.

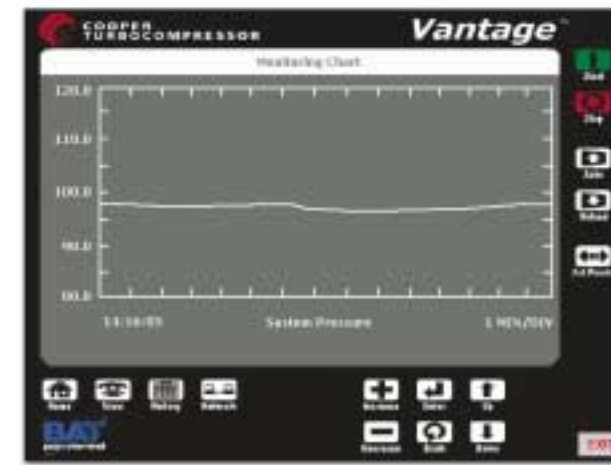

The Turbo Air® 2000 Compressor features the Vantage™ High Performance Control System as standard equipment for maximum ease of use and compressor efficiency. The Vantage™ system was developed as a result of our strategic alliance with Bay Controls, known in the industry for its expertise in designing compressor controls and compressed air solutions.

The most efficient and reliable compressor control available anywhere

- The Vantage™ system uses Polytropic Head and inlet flow to accurately predict the true surge point relative to changing operating conditions.
- The Vantage™ control strategy maximizes a compressor's operating throttle range, increasing useable turndown and substantially reducing or eliminating wasteful compressor blow-off.
- Reacts to large system demand changes better than any other controller.
- Results in optimal operating efficiency and reliability in compressed air supply.

Saves energy to save you money

- Offers greater operating turndown and true system pressure control for significant energy savings.
- Typically delivers 10-20% greater range over other OEM controllers.
- Can result in tens of thousands of dollars in annual energy savings.

Easy-to-use information display

- Full page, 640 x 480, graphic back-lit LCD display for the user interface with an integrated 15 key, tactile keypad.
- Provides 24 lines by 80 characters of detailed information on the operational condition and settings of the controller.
- Large, back-lit display is easily read under all ambient lighting conditions.

Monitoring Views and History

- Event history provides critical diagnostic and operating information, listing the last 256 events, including start-up, shutdown, set point changes, and more.
- Protection history provides operating information listing the last 256 alarm warnings and trips.
- Monitoring view provides a complete picture of compressor operation in real time.

Compressor Networking for further operational savings

- Compressor Networking can operate up to 32 compressors as one coordinated system.
- Assures that each compressor is operating at peak efficiency levels, with the ability to respond to large changes in system demand.

Optional features

- **Performance History** maintains a record of the power consumption, compressor and system mass flow, and compressor and system efficiency for twelve months.
- **Operation Scheduler** enables automatic changes to system pressure setpoint, maximum load setpoint, and start and stop compressors at a configurable date and time.
- **VantagePoint™** Web-based monitoring allows 24/7 connectivity and data acquisition to manage your compressed air system wherever you are - at home, on the road or in your office.
- **Vantage+™ Engineering** provides additional consulting services such as audits, measurement and verification, metering and design services, as well as complete training.

Cooper Turbocompressor Parts and Service Support

Everything you need to maintain peak performance

Cooper Turbocompressor centrifugal compressors have been designed and manufactured in the same facility in Buffalo, New York, USA for forty years. These Turbo Air® machines have more recently been produced as Cooper Turbocompressor products. No one can service these machines better than the original manufacturer's service network.

Cooper Turbocompressor makes the replacement parts to the same high quality and up-to-date technology as those in new compressors.

An extensive inventory of parts including genuine factory parts is maintained. A computerized inventory system assures fast turnaround and delivery.

The best source for compressor upgrades

Cooper Turbocompressor products are long-life products that can be upgraded to gain advantages of new developments in aerodynamics or control technology. In addition, your system demand may change which can be matched with a simple modification to your existing compressor.

Service from the people who know Cooper Turbocompressor best.

Cooper Turbocompressor is committed to keeping your Turbo Air® 2000 compressor running at peak performance. Cooper Turbocompressor employs the most knowledgeable and experienced field service technicians in the industry.

These technicians offer faster response to your needs and have superior knowledge of Cooper Turbocompressor products to solve problems fast.

An extensive, highly trained worldwide distributor service network provides efficient and responsive support.

The best source for your training needs.

The training schools at the Buffalo, New York, USA factory provide all necessary hands-on training to properly maintain your centrifugal compressor. On-site training can also be provided.



Meeting your needs with genuine factory parts.

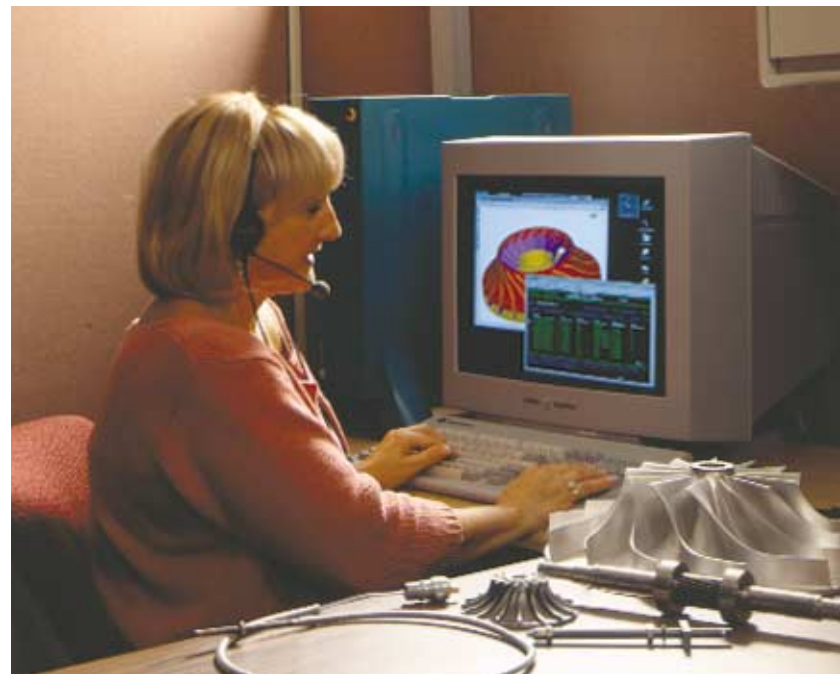

Cooper Turbocompressor's worldwide service organization responds to your needs quickly and effectively, 24 hours a day.

Weights and Dimensions

