

## Regeneration takes place independently of the main process air flow



PNEUMATIC PRODUCTS

### DESCRIPTION

The Century Series CAB II Desiccant Air Dryer is designed for flows ranging from 1,200 to 13,000 scfm at pressures ranging from 60 to 150 psig, and provide -40°F pressure dewpoint. With the new multi-stage turbine, the CAB II has been designed to meet industries' increasingly stringent noise requirements.

### APPLICATIONS

The CAB II Dryer serves Instrument, Fluid Power, and Process Air applications. The dryer may be used in continuous or intermittent service and when used in conjunction with PPC coalescing filters, is suitable for use downstream of lubricated or oil-free compressors. The CAB II Dryer is designed for the severest industrial environments.

### FEATURES AND BENEFITS

- Ambient Air used for Regeneration: *No process gas lost to purge.*
- Convection Regeneration: *Prolonged desiccant life.*
- Downflow Drying: *Minimizes desiccant attrition.*
- Century Series Valves: *Reliable/dependable operation.*
- AMLOC® Controls: *Energy savings/diagnostics. Lifetime probe guarantee.*
- PPC Pleated Coalescing Filters: *(.0014 ppmw) Long cartridge life, enhances dryer performance, extends desiccant life.*
- PPC Pleated Particulate Filters: *(0.9 micron) Long cartridge life and no desiccant downstream.*
- Centrifugal Blower: *Reduced noise levels, adjustable flow rates to meet regeneration needs.*
- Counter-Current Regeneration: *Ensures low dewpoint production.*
- Vessels & Manifolds: *Shot blast, zinc chromate primer, and 2-part epoxy paint for superior corrosion resistance.*
- Fill and Drain Ports: *Easy desiccant changeout.*
- Removable Stainless Steel Support & Diffuser Screens: *Easy to service and clean.*
- High-Capacity Desiccant Charge: *For low dewpoint production.*
- Heater/Valve Interlocks: *Safety.*
- Heater/Blower Interlocks: *Safety.*
- Hot Piping Insulation: *Safety.*
- Separate Enclosures for High Tension and Controls: *Safety.*

## Century Series™ Dryers The CAB II Blower Regenerated Dryer



# ADC Control System with AMLOC® Moisture Load Control

## CONTROLS-MONITORS-DIAGNOSTICS

The synoptic display and information center work together to provide automatic operation of the dryer, monitor all dryer functions, and diagnose system faults.

### Features

- LED Status Display **30 times** brighter than standard industrial LED's
- Liquid crystal display with LED adjustable back lighting for wide variety of ambient lighting conditions

### Operator Information - Status Menu

- Dryer Operation Normal
- Switchover
- Right or Left chamber depressurizing, seconds displayed
- Right or Left chamber repressurizing, seconds displayed
- Right or Left chamber heating, minutes displayed
- Right or Left chamber sweeping, minutes displayed
- Right or Left chamber holding, total time displayed
- Right or Left chamber depressurization failure
- Right or Left chamber repressurization failure
- Right or Left chamber low on-line pressure
- Right or Left AMLOC® Failure
- Right or Left High Humidity Alarm
- Clear Alarm (All Alarms Clear)
- Heater Over Temperature
- Blower Motor Overload
- Inlet Switching Failure
- Outlet Switching Failure
- AMLOC® probe frequency reading Right and Left chambers
- Pressure high/low Right and Left chambers
- Loss of Power Alarm

## PROGRAMMING CAPABILITIES

To provide additional flexibility and protection for PPC systems, the PPC dryer has the ability to be changed in the field to match the user's operating conditions.

### Configure Messages Menu

- Pressure Switches: Enabled/Disabled
- Proximity Switches: Enabled/Disabled
- Communication: Baud Rate



ADC CONTROLS

## RS 232 SERIAL COMMUNICATION

The RS-232 Serial Communication Port is supported by a passive, byte for byte, monitor-only protocol. This allows monitoring of the dryer cycle status including alarms, configuration, and maintenance set points.

## HISTORY OF DRYER OPERATION

The history of dryer operation is maintained by storing run information and up to 20 alarms. This provides operators and "Service Technicians" with readily available information for diagnostics, repair and maximum uptime. The History Messages Menu displays the following information:

### History Messages Menu

- AMLOC® savings (hours)
- Last Dry Right Chamber (hours)
- Last Dry Left Chamber (hours)
- Current Dry (hours)
- Current Heat (minutes)
- Current Hold (hours)
- Run Time (days)
- Last Heat Right Chamber (minutes)
- Off Time (days)
- Last Heat Left Chamber (minutes)
- Total Time (days)
- Last Hold Right Chamber (hours)
- Alarms (messages)
- Last Hold Left Chamber (hours)
- Current Hold (hours)

# The Need for Energy Management and PPC's Patented AMLOC® System

Practical experience has shown that dryers seldom operate at maximum design moisture conditions. In fact, **operating at 20 to 30 percent of the design load is quite common.** Our

AMLOC® Energy Management System recognizes this situation and automatically adjusts the dryer operation to compensate for changes in operating conditions.

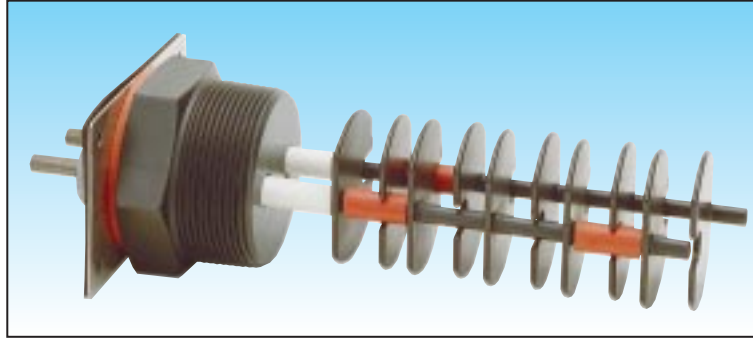

**AMLOC® PROBE Proven in over 25,000 Applications with a Lifetime Warranty and no calibration requirements.**

## MAXIMIZE ENERGY SAVINGS

AMLOC® (Automatic Moisture Load Control) **maximizes energy savings and minimizes maintenance costs.** It also provides superior dryer diagnostics and alarm capabilities.

AMLOC® assures full utilization of the moisture holding capacity of the desiccant bed before terminating the drying cycle and proceeding to regenerate the bed, thus limiting the number of regenerations to the minimum possible. This not only saves energy, but also reduces attrition and greatly enhances desiccant life by minimizing the exposure of the desiccant to thermal stresses and flow reversals.

## Century Series Valves:

### Dependable Operation By Design

Over 40 years of dryer manufacturing experience has made Pneumatic Products Corporation an authority on valves for air drying applications. The ideal valve for use on desiccant dryers is a full-ported, poppet-type, piston-actuated, non-lubricated, pilot-air controlled valve. The valve must be manufactured from materials which can withstand hostile operating conditions: **stainless steel internals, steel valve bodies, and high temperature elastomer seals.**

## FEATURES AND BENEFITS

<b>Cycle Tested to 500,000 cycles:</b>	Reliability and long life.
<b>Full-ported, poppet operation:</b>	Low $\Delta P$ through the valve at line pressure. No flow interruption during switching. Linear motion of poppet operation results in the least amount of seal wear and prevents seat abrasion caused by friction.
<b>Pilot air control:</b>	Positive control of switching valves under all operating conditions.
<b>Elastomer seals:</b>	Positive seal even when small amounts of solid contaminants are present. High reliability without need for lubrication and frequent maintenance.
<b>Special Turcite sliding seals:</b>	Widely used in military and industrial applications involving wear particles, and corrosive contaminants. Low wear and long life.
<b>Forged steel bodies:</b>	Provide safe operation.
<b>Stainless steel internals:</b>	Critical components of Century Valves are constructed of stainless steel resisting the effects of abrasive and corrosive components.
<b>Tie rod construction:</b>	Permits valve maintenance without the use of special tools.
<b>Position indicators, Proximity Switches:</b>	Fast, simple monitoring of valve operation for autodiagnosics.

The PPC  
is used a  
outlet val  
Century s

## CAPACITANCE MOISTURE SENSING

The AMLOC® Energy Management System is *unlike any other demand cycle control. Only AMLOC® senses the actual condition of the desiccant bed.* This unique feature utilizes an industrial grade capacitance probe imbedded in the desiccant. The probe senses the actual moisture content of the desiccant.

Since the moisture content is sensed directly by the probe, accurate readings are assured. No filters or other devices are required between the moisture and the sensor, eliminating the possibility for inaccurate or misleading readings.

The microcomputer-based control ensures system reliability and is fail-safe. AMLOC®'s operation can be monitored with the comprehensive easy-to-read liquid crystal display supplied as standard.

Specifically designed for the severest industrial environments, PPC's AMLOC® system has been field proven in over 25,000 installations since 1978.

## LIFETIME WARRANTY

Made of Teflon® coated stainless steel, the AMLOC® probe is immune to contamination. Backed by a *lifetime replacement warranty*, its rugged industrial design eliminates the need to stock replacement sensors. Additionally, this PPC patented probe *never requires calibration throughout the entire life of the dryer!*

### Example of Annual Moisture Load Factor (M.L.F.) and Potential Energy Savings

	Design Conditions	Annual Average	M.L.F.
FLOW:	1000 SCFM	800 SCFM	80%
TEMP:	100 Deg. F	95 Deg. F	80%
PRESS:	100 PSIG	100 PSIG	100%
R.H.:	100%	80%	80%
			51% M.L.F.

**Result** 51% Annual average moisture load results in **49% savings in energy consumption!!**

The PPC 3-way Valve has an inlet and outlet on all sides.

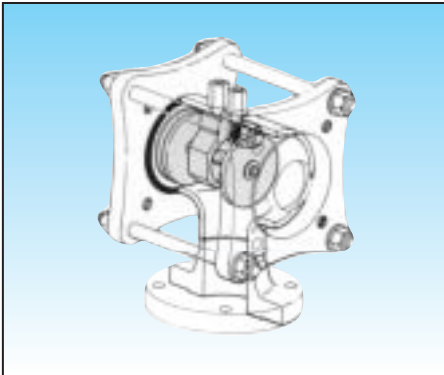

The PPC 2-way Valve is similar in construction to the 3-way valve and is utilized as the exhaust valve.

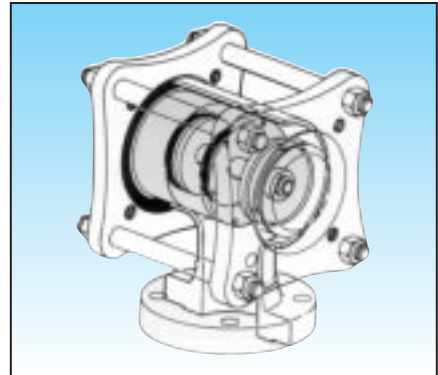

The PPC Check Valve is used to direct purge flow to the depressurized bed for regeneration. The Check Valve has been designed to eliminate chatter at low flow rates.

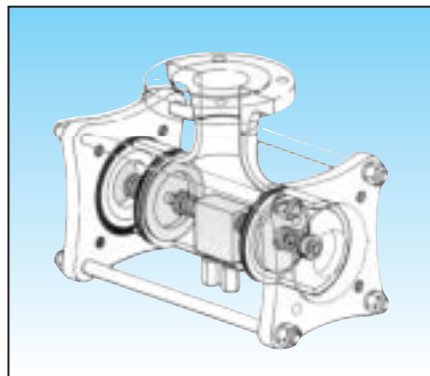

**PNEUMATIC PRODUCTS**

## HOW IT WORKS

Inlet air enters through the PPC coalescing prefilter assembly where all liquid droplets, mists and aerosols are removed. The liquid-free, but saturated air then enters the 3-way inlet valve. It is directed down through the on-line chamber, where the water vapor is removed. The dry air flows through the lower 3-way outlet valve and then through the PPC afterfilter, where any fine air-borne desiccant particles are removed.

While one chamber is on-line, the off-line chamber is regenerated in two steps. First the off-line chamber is depressurized in a downward direction. This keeps the desiccant bed packed and prevents fluidization. After depressurization, the depressurization valve is closed and the upper 2-way exhaust valve is opened.

Atmospheric purge air from the centrifugal blower is then passed through a purge heater and upward through the off-line desiccant bed. The purge air in combination with the heat removes the moisture from the desiccant bed.

If the PPC AMLOC® probe senses a low desiccant moisture level in the on-line bed, the drying time for that bed is extended. The off-line tower is repressurized after being regenerated and allowed to cool. Therefore, the blower and the heater are only run when required.

## SERVICE INFORMATION

Service Requirements for PPC Air Dryers are minimal due to the long service life engineered and designed into each component part. However, much like changing the oil in your car, there are recommended preventive maintenance procedures to ensure long, troublefree performance of PPC purification systems. The Service Menu provides reminders when service is due. The Service Message Menu displays the following information:

### Service Information and Functions — Menu

- Program Version/Catalog No.
- Filter Usage: X of X weeks
- Valve Usage: X of X weeks
- Desiccant Usage: X of X weeks
- Service requirements can be reset/ reprogrammed to meet specific customer conditions and requirements.

CAB II FLOW DIAGRAM

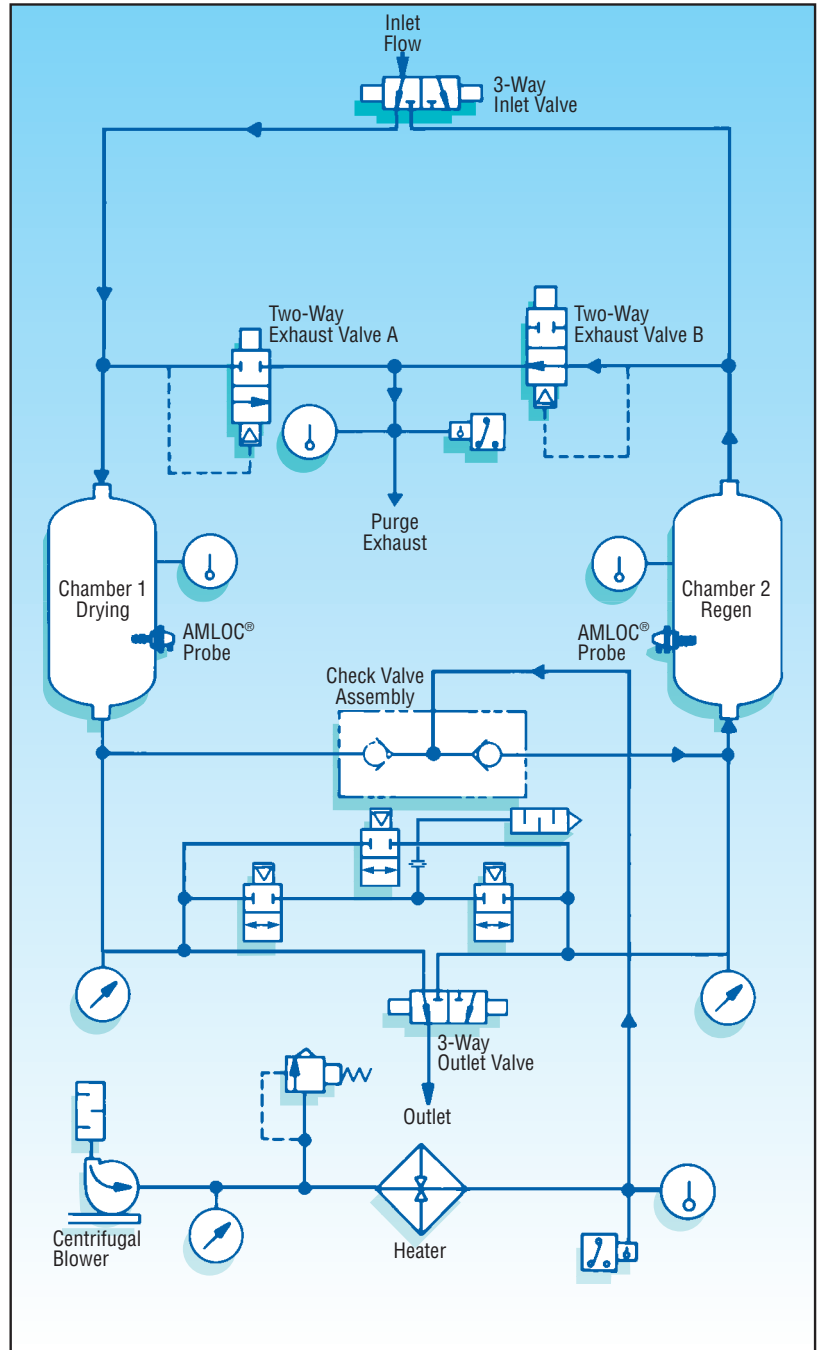

*Depending on system design, regeneration may be closed or open loop.*



PNEUMATIC PRODUCTS

# SELECT A "SYSTEM"

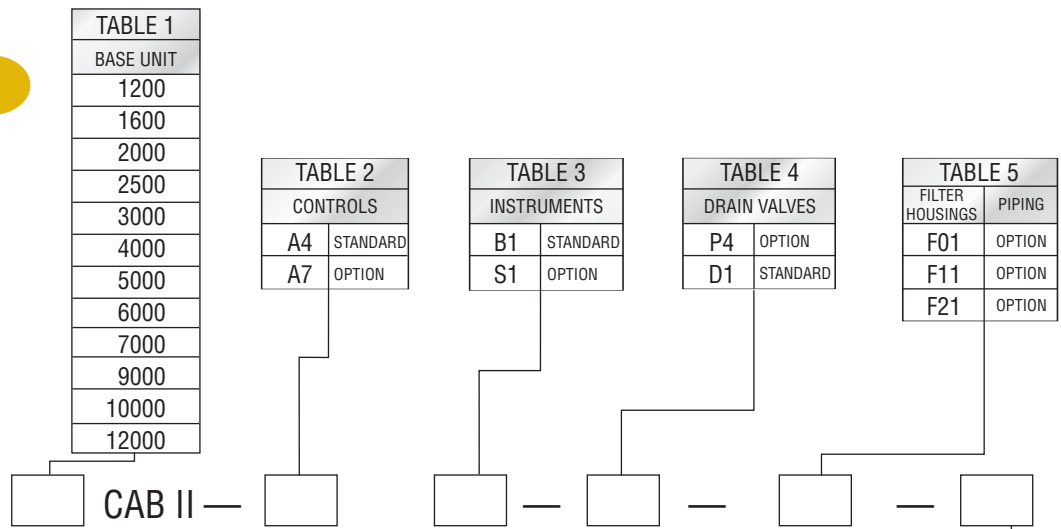

TABLE 1 — Base unit includes vessels, manifolds, Century Series Valves, removable stainless diffuser screens, Nema 4 AMLOC® Control for energy savings, 150# brass instrument package and PPC's standard corrosion resistant non-plugging muffler. Also includes complete Blower/Heater Regeneration package.

TABLE 2 — A4 AMLOC® includes Energy Management System, diagnostics, high-humidity alarm, indicating lights and switching failure. A7 Option: only with steam heater option (Consult Factory). AMLOC® electricals meet Class I, Group D, Div. II

TABLE 3 — Instrument package includes inlet/outlet pressure gauges, chamber pressure gauges, purge pressure gauge, AQUADEX® moisture indicator, .9 micron absolute pilot air filter and filter block valve. Stainless steel available as an option.

TABLE 4 — Drain Valves: "D1" for DDV-2000 Demand Drain, and P4 for Programmable electric solenoid.

TABLE 5 — Filter Housings/Piping Options

TABLE 6 - OPTIONS	
CODE	DESCRIPTION
ALUMINUM ΔP GAUGES	
AL1	• Qty 1 (ΔP System)
AL2	• Qty 2 (ΔP F01/F11)
AL3	• Qty 3 (ΔP F01/F11 & System)
AL4	• Qty 4 (ΔP F21)
AL5	• Qty 5 (ΔP F21 & System)
SST ΔP GAUGES	
SS1	• Qty 1 (ΔP System)
SS2	• Qty 2 (ΔP F01/F11)
SS3	• Qty 3 (ΔP F01/F11 & System)
SS4	• Qty 4 (ΔP F21)
SS5	• Qty 5 (ΔP F21 & System)
BB	BLOCK VALVES (Brass) (Kit of 5)
BS	BLOCK VALVES (SST) (Kit of 5)
FLOW METERS (8 wks lead-time)	
F1	• 1200 - 3000 CAB
F2	• 4000 - 5000 CAB
F3	• 6000 - 9000 CAB
I	INSULATION
R	575 VOLT PACKAGE

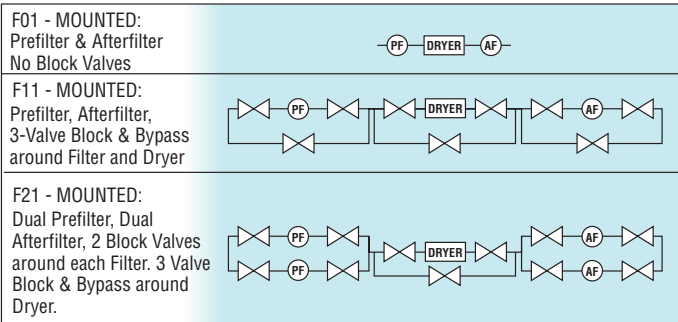

APPROXIMATE OPERATING DIMENSIONS AND WEIGHTS					
Model Number	Connection Size	Height	Width	Depth	Weight (lbs.)
1200CABII	3" Flange	136"	79"	51"	3,900
1600CABII	3" Flange	128"	90"	59"	5,300
2000CABII	4" Flange	140"	90"	59"	6,300
2500CABII	4" Flange	152"	90"	59"	7,300
3000CABII	4" Flange	147"	105"	69"	9,500
4000CABII	6" Flange	156"	125"	73"	13,600
5000CABII	6" Flange	156"	139"	73"	16,600
6000CABII	6" Flange	161"	153"	95"	21,000
7000CABII	8" Flange	178"	153"	95"	23,700
9000CABII	8" Flange	181"	168"	101"	28,200
10000CABII	8" Flange	184"	184"	101"	33,000
12000CABII	10" Flange	196"	184"	101"	37,300

Because of our policy of continuous improvement, some information, specifications and dimensions contained herein may be revised. For confirmed accuracy, always refer to factory submittals.

DISTRIBUTED BY:

